

# BENCH CENTERS

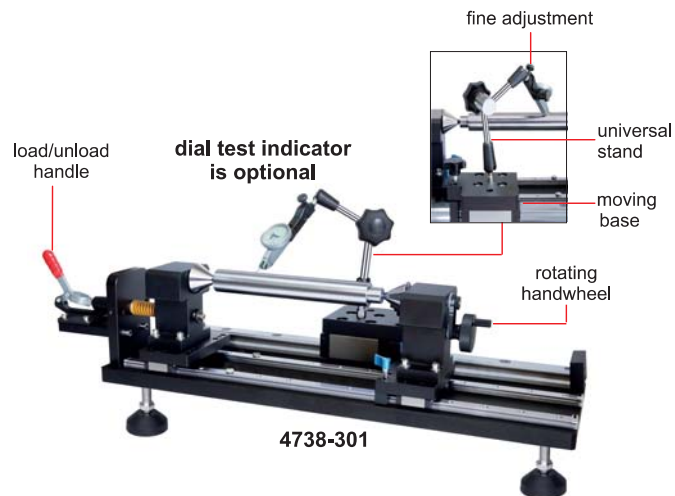

dual base (optional)

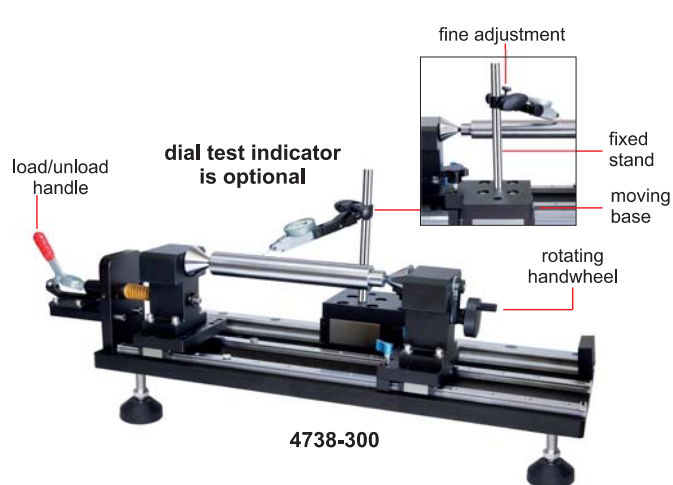

standard rod (included)

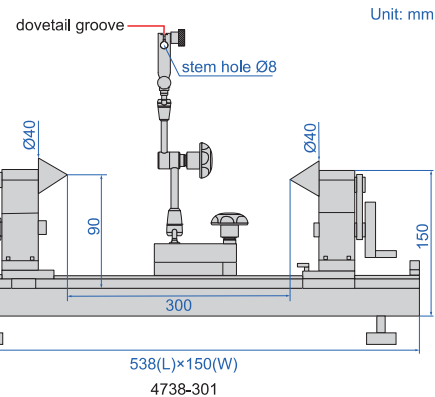

- Quick positioning, suitable for mass measurement
- Suitable for cylinders with outside diameter  $\text{Ø}3\text{-}180\text{mm}$  or inside diameter  $\text{Ø}1\text{-}40\text{mm}$
- Supplied with standard rod to verify accuracy
- Optional accessory: dial test indicators

Code	Center height	Distance between two centers	Runout accuracy	Weight	Load	Remark
4738-300	90mm	300mm	2 $\mu\text{m}$	15kg	20kg	fixed stand, high accuracy, inconvenient operation
4738-301	90mm	300mm	2 $\mu\text{m}$	15kg	20kg	universal stand, low accuracy, convenient operation